

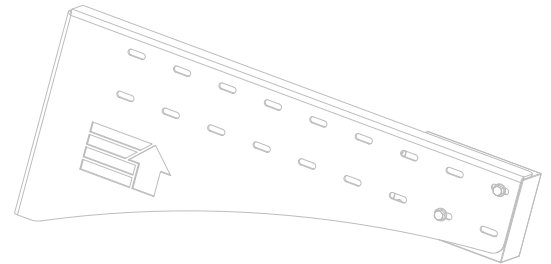

More information
on the product page

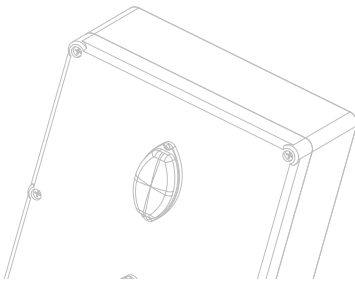
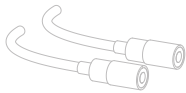
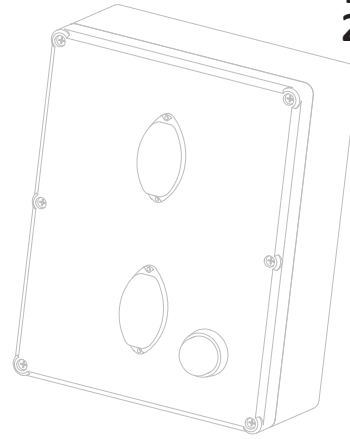
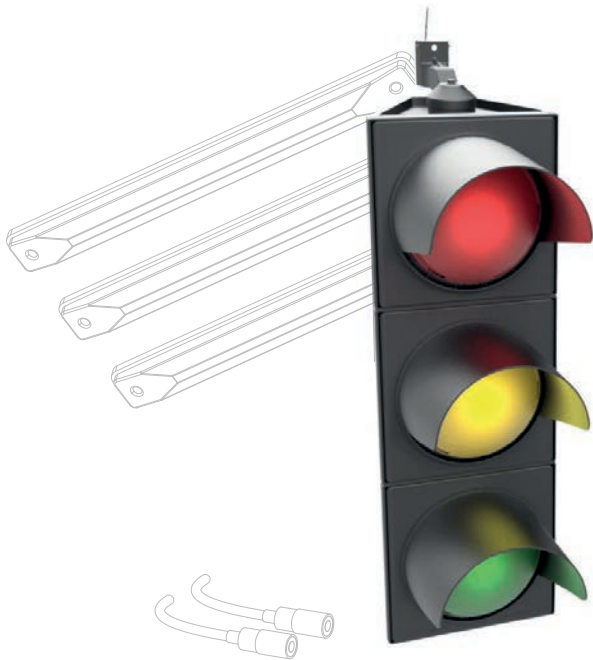

AMTR-ZSD

Proximity docking system

- quick and safe loading
- protection and safeguarding of the handling system
- increase in working ergonomics
- improving staff communication with the driver
- compatibility with external systems



AC 082

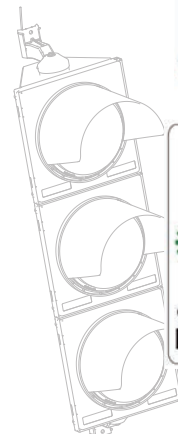

General information









This proximity docking system is an electronic system based on a proximity sensor combined with a traffic light to improve the logistical process of unloading and increase safety. It enables the efficient handling of goods and supports the work of drivers when docking vehicles. The system automatically informs the driver of the docked vehicle and the operating personnel inside the dock that the vehicle is ready for work.

Characteristics

- the external lights inform the driver of the distance to the dock, and the internal lights inform the driver that the vehicle is at the dock and work can begin,
- the light system operates on the basis of a proximity sensor which is fitted to the front of the platform and signal lamps located outside and inside the dock.

AMTR-ZSD V1 Docking System

The ZSD V1 light system is based on a proximity sensor and external signalling consisting of a green and red light informing the driver that he has reached a designated place and that the vehicle must stop. It is possible to link the system to the door, which gives feedback on the start of service.

STAGE	ACTIVITY DESCRIPTION	EXTERNAL LAMP	INTERNAL LAMP
1	The dock is at rest - ready for docking		
2	The vehicle has arrived at the designated location*.		
3	Closing the door at the end of vehicle operation		
4	Vehicle departure from		

* If vehicle operation does not start within 3 minutes of the vehicle being docked, the programme automatically goes to stage 3.

Technical data

Application

Power supply

Type of sensor

Adjustable detector range

Lamp wattage

Degree of protection

Docking systems

230 VAC

Ultrasonic PNP

10- 1000 mm

40 W

IP67

The set includes:

















- Control box
- Proximity sensor
- Main signal with red and green light
- Installation wiring set



AMTR-ZSD V2 Docking System

The ZSD V2 light system is based on 2 proximity sensors and external signalling consisting of a green, yellow and red light informing the driver that the vehicle is approaching and then arriving at a designated place and needs to stop. It is possible to link the system to the door, which gives feedback on the start of service.

The ZSD V2 system offers full compatibility with the AMTR-K chock with optical sensor and air seal, thus gaining greater safety during vehicle handling and reducing the risk of damage to dock systems.

STAGE	ACTIVITY DESCRIPTION	EXTERNAL LAMP	INTERNAL LAMP	UP
1	The dock is at rest - ready for docking			OFF
2	The vehicle is approaching the stopping point			OFF
3	The vehicle has arrived at the designated location			OFF
4	Underlying a wedge			OFF
5	Pressing the START button			ON
6	Closing the door and folding UP			ON
7	Waiting for the wedge to be removed from under the wheel			OFF
8	Vehicle departure from the dock			OFF

Technical data

Application

Power supply

Type of sensor

Adjustable detector range

Lamp wattage

Degree of protection

Handling systems

230 VAC

Ultrasonic PNP

10- 1000 mm

40 W

IP67















The set includes:

- Control box
- Proximity sensor - 2 pcs
- Main signal with red, yellow and green light
- Installation wiring set



AMTR-ZSD V3 Docking System (Light Guide)

The ZSD V3 system is based on a system of LED lights to assist the driver because they are positioned at the optimum height for the driver, so that he does not have to constantly observe both the position of the wheels in relation to the steel guides and the distance from the dock wall. The use of the ZSD V3 system allows the complete elimination of traditional guidance systems, thus providing more space in the yard without obstacles, which makes snow removal easier in winter conditions. The ZSD V3 system is characterised by its long service life and low power consumption.

SITUATION	EXTERNAL LIGHT	INTERNAL LIGHT
No articulated lorry		
Articulated lorry in place		
Opening the door		
Loading / unloading		
Closing the door		
After pressing the button		
The articulated lorry drove off		

The set includes:

Technical data

Application

Power supply

Type of sensor

Sensor range

LED strip power

Degree of protection

Handling systems

230 VAC

Reflective PNP

10- 2000 mm

0.7 W

IP67

W skład zestawu wchodzi:

- Control box
- Reflective sensor
- Sensor holder
- White LED strip - 2 pcs
- Red LED strip - 1 pc
- Installation wiring set



Flashing light