

Pre-frame for the dock leveller  
with telescoping lip  
**AMTRV-PRO**

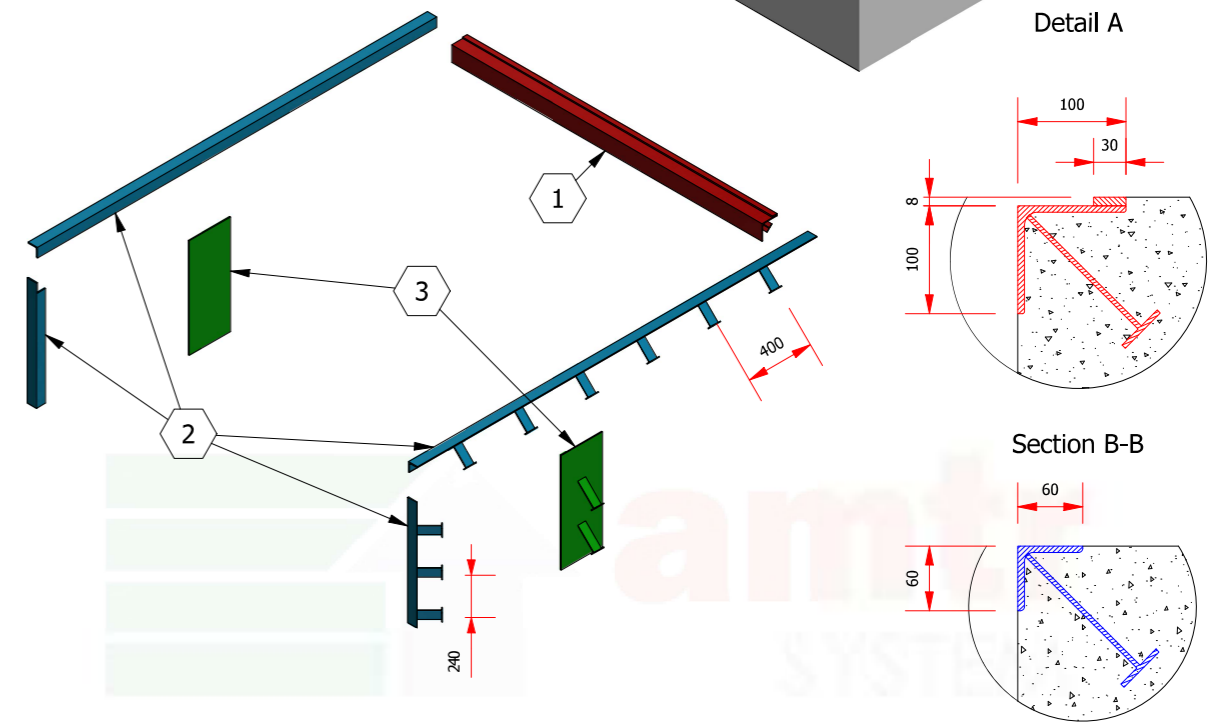
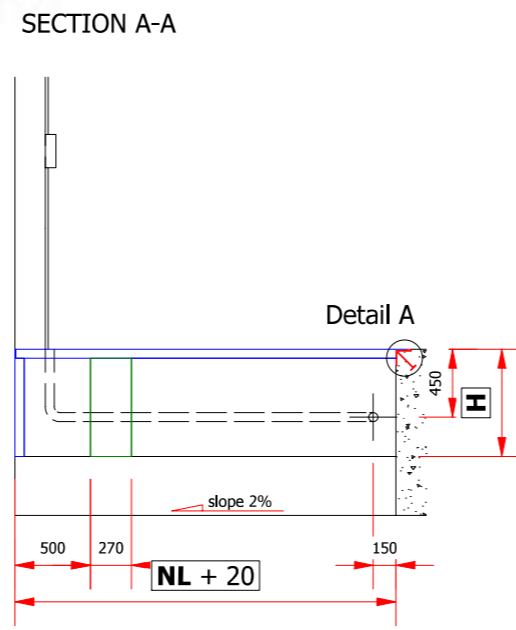
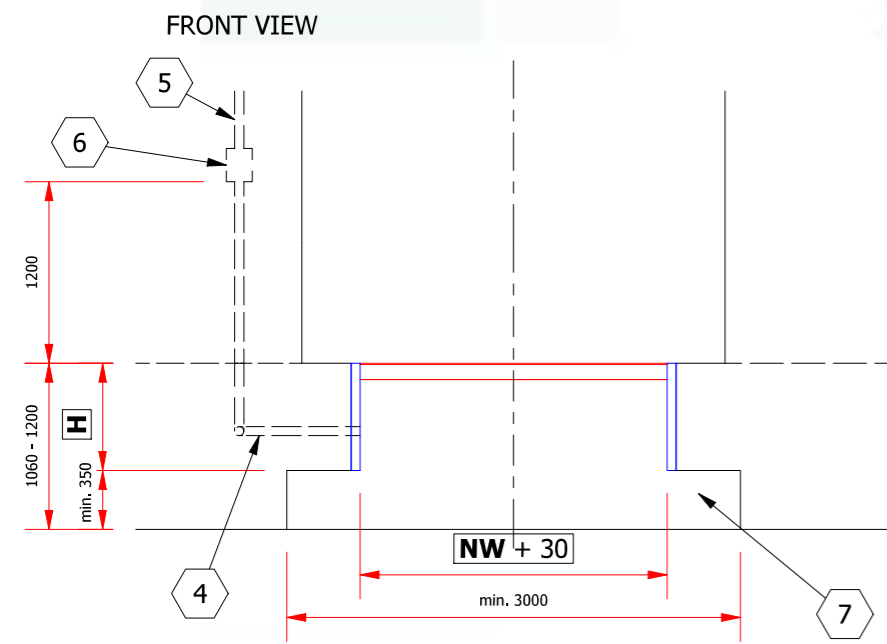
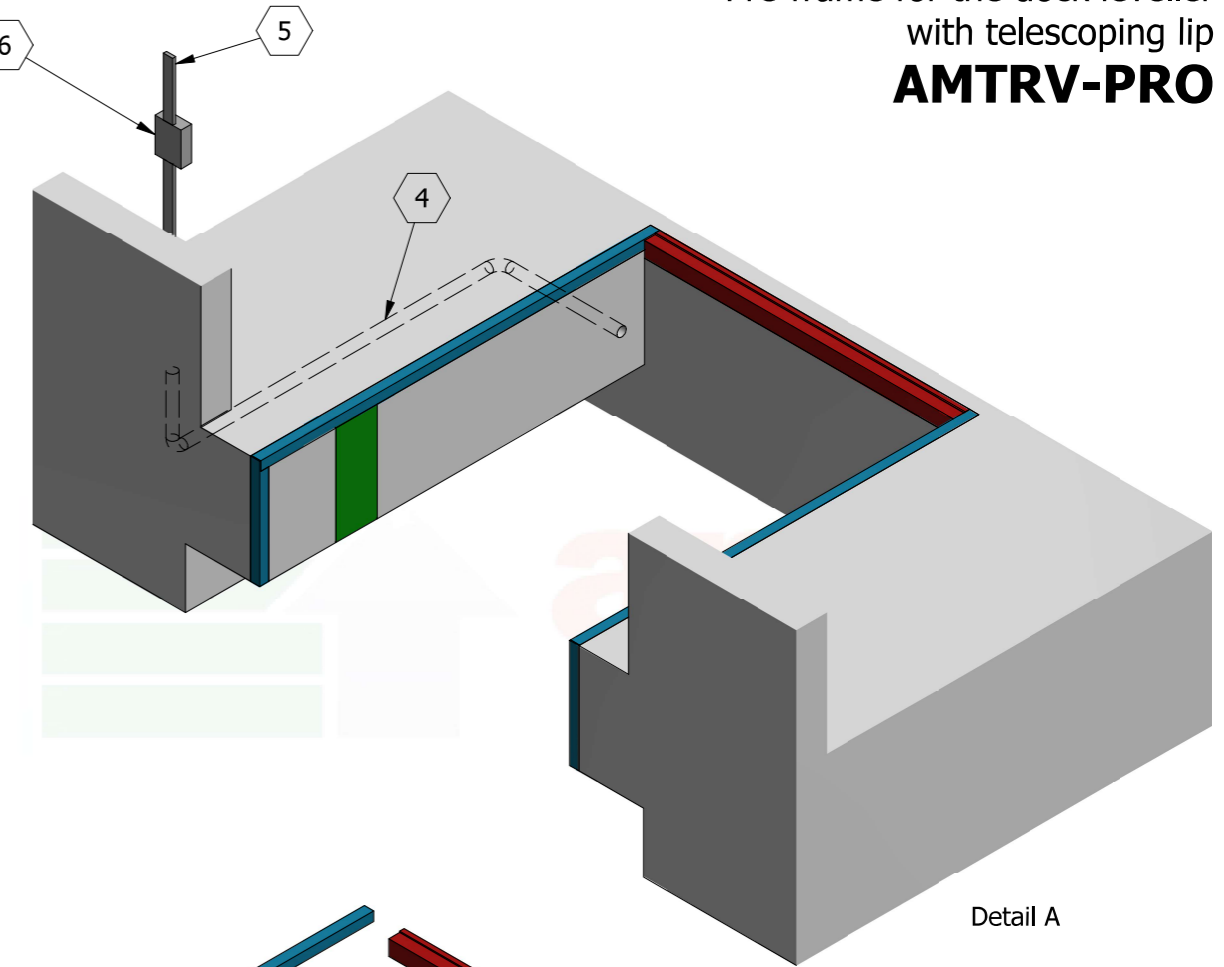
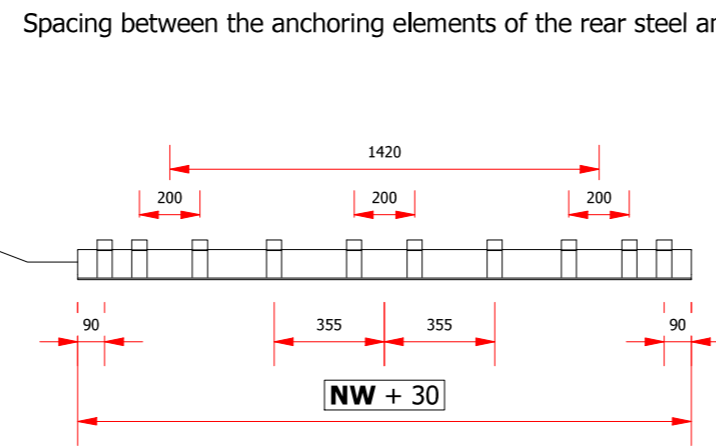
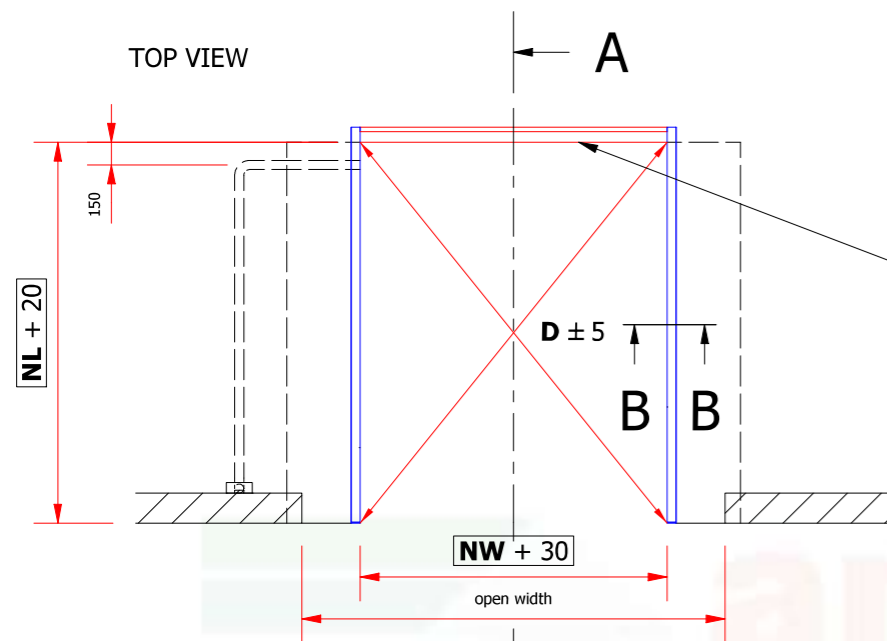

Description:

1. Supply and fix pit box, edge angles 100x100x8 and flat bar 30x8 (Detail A).
2. Supply and fix pit box, edge angles 60x60x8. It is advised to fix frame along with flooring reinforcement.
3. Steel plate 270x650x6 (welding site with the leveller).
4. PCV electrical conduit (min.  $\varnothing 60$ ) for electrical connections between dock leveler and control panel.
5. Power supply - 400 V, 50 Hz, 3 phase, neutral and earth terminating in isolator fixed in position shown. Hydraulic unit motor power: 1,5 kW. Recommended wire cross-section: 2,5 mm<sup>2</sup>.
6. Control panel. Provide suitable mounting surface for control panel; dimensions 180x250mm.
7. Bay for car lift.
8. At bumper fixation points forces of 59kN to be expected on prefabricated concrete with 30tons lorries and a velocity of 5km/h.

<b>NW</b>	- nominal width	2000	2000	2000	2250	2250	2250
<b>NL</b>	- nominal length	2000	2500	3000	2000	2500	3000
<b>NW + 30</b>	- foundation width	2030	2030	2030	2280	2280	2280
<b>NL + 20</b>	- foundation length	2020	2520	3020	2020	2520	3020
<b>H</b>	- construction height	710	710	710	710	710	710

Designed by P. Pomykała	Checked by M. Palega	Approved by G. Mazurkiewicz	Date X : X	Date 14.10.2021	A3
----------------------------	-------------------------	--------------------------------	---------------	--------------------	----



Pit drawing for the dock leveller AMTRV-PRO

AMTRV-PRO	Edition 1.2	Sheet 1 / 1
-----------	----------------	----------------

\* The drawing is an illustrative drawing, not made to scale. Detailed technical solutions may differ from the ones shown in the drawing.